

Approval body for construction products
and types of construction

Bautechnisches Prüfamt

An institution established by the Federal and
Laender Governments



European Technical Assessment

ETA-17/0605
of 28 August 2017

English translation prepared by DIBt - Original version in German language

General Part

Technical Assessment Body issuing the
European Technical Assessment:

Deutsches Institut für Bautechnik

Trade name of the construction product

blaugelb screws

Product family
to which the construction product belongs

Screws for use in timber constructions

Manufacturer

Meesenburg Großhandel KG
Höfinger Straße 16
70499 Stuttgart
DEUTSCHLAND

Manufacturing plant

C1230, M1222, D1030, W1239, O1209, V1430
W1243, M1105, O1213, O1603, C1604

This European Technical Assessment
contains

31 pages including 5 annexes which form an integral part
of this assessment

This European Technical Assessment is
issued in accordance with Regulation (EU)
No 305/2011, on the basis of

European Assessment Document (EAD)
130118-00-0603

The European Technical Assessment is issued by the Technical Assessment Body in its official language. Translations of this European Technical Assessment in other languages shall fully correspond to the original issued document and shall be identified as such.

Communication of this European Technical Assessment, including transmission by electronic means, shall be in full. However, partial reproduction may only be made with the written consent of the issuing Technical Assessment Body. Any partial reproduction shall be identified as such.

This European Technical Assessment may be withdrawn by the issuing Technical Assessment Body, in particular pursuant to information by the Commission in accordance with Article 25(3) of Regulation (EU) No 305/2011.

English translation prepared by DIBt

Specific Part

1 Technical description of the product

Blaugelb R 2, drilling screws, wood construction screws, fully threaded wood construction screws are screws made from special carbon or stainless steel. Screws made from carbon steel are hardened, electrogalvanised and yellow or blue chromated. The outer thread diameter is not less than 3.0 mm and not greater than 12.0 mm. The overall length of the screws is ranging from 16 mm to 500 mm. Further dimensions are shown in Annex 5.

2 Specification of the intended use in accordance with the applicable European Assessment Document

The performances given in Section 3 are only valid if the blaugelb screws are used in compliance with the specifications and conditions given in Annex 1 to 4.

The verifications and assessment methods on which this European Technical Assessment is based lead to the assumption of a working life of the blaugelb screws of at least 50 years. The indications given on the working life cannot be interpreted as a guarantee given by the producer, but are to be regarded only as a means for choosing the right products in relation to the expected economically reasonable working life of the works.

3 Performance of the product and references to the methods used for its assessment

3.1 Mechanical resistance and stability (BWR 1)

Essential characteristic	Performance
Dimensions	See Annex 5
Characteristic yield moment	See Annex 2
Characteristic withdrawal parameter	See Annex 2
Characteristic head pull-through parameter	See Annex 2
Characteristic tensile strength	See Annex 2
Characteristic yield strength	See Annex 2 and 3
Characteristic torsional strength	See Annex 2
Insertion moment	See Annex 2
Spacing, end and edge distances of the screws and minimum thickness of the wood based material	See Annex 2
Slip modulus for mainly axially loaded screws	See Annex 2

English translation prepared by DIBt

3.2 Safety in case of fire (BWR 2)

Essential characteristic	Performance
Reaction to fire	The screws are made of steel classified as Euroclass A1 in accordance with EC decision 96/603/EC, as amended by EC decision 2000/605/EC.

3.3 Safety and accessibility in use (BWR 4)

Same as BWR 1

4 Assessment and verification of constancy of performance (AVCP) system applied, with reference to its legal base

In accordance with EAD No. 130118-00-0603, the applicable European legal act is: 97/176/EC.
The system to be applied is: 3

5 Technical details necessary for the implementation of the AVCP system, as provided for in the applicable EAD

Technical details necessary for the implementation of the AVCP system are laid down in the control plan deposited with Deutsches Institut für Bautechnik.

Issued in Berlin on 28 August 2017 by Deutsches Institut für Bautechnik

Dr.-Ing. Lars Eckfeldt
p. p. Head of Department

beglaubigt:
Dewitt

Annex 1 Specifications of intended use

A.1.1 Use of the blaugelb screws only for:

- Static and quasi-static loads

A.1.2 Base materials

The screws are used for connections in load bearing timber structures between wood-based members or between those members and steel members:

- Solid timber (softwood) according to EN 14081-1¹,
- Glued laminated timber (softwood) according to EN 14080²,
- Laminated veneer lumber LVL of softwood according to EN 14374³, arrangement of the screws only perpendicular to the plane of the veneers,
- Glued solid timber (softwood) according to EN 14080 or national provisions that apply at the installation site,
- Cross-laminated timber according to European Technical Approvals/Assessments or national provisions that apply at the installation site,
- Oriented Strand Board, OSB/3 or OSB/4 according to EN 300⁴ and EN 13986⁵ with a minimum thickness of 18 mm.

The screws may be used for connecting the following wood-based panels to the timber members mentioned above:

- Plywood according to EN 636⁶ and EN 13986,
- Oriented Strand Board, OSB according to EN 300⁷ and EN 13986,
- Particleboard according to EN 312⁸ and EN 13986,
- Fibreboards according to EN 622-2⁹, EN 622-3¹⁰ and EN 13986,
- Cement-bonded particle boards according to EN 634-2¹¹ and EN 13986,
- Solid-wood panels according to EN 13353¹² and EN 13986.

Wood-based panels shall only be arranged on the side of the screw head, except OSB/3 and OSB/4 panels with a minimum thickness of 18 mm.

Blaugelb-screws with an outer thread diameter of at least 6 mm may be used for the fixing of thermal insulation material on top of rafters or on wood-based members in vertical façades.

Blaugelb wood construction screws with $d = 8$ mm and a full thread may be used for reinforcing of timber structures perpendicular to the grain.

1	EN 14081-1:2005+A1:2011	Timber structures – Strength graded structural timber with rectangular cross section – Part 1: General requirements
2	EN 14080:2013	Timber structures - Glued laminated timber and glued solid timber - Requirements
3	EN 14374:2004	Timber structures - Structural laminated veneer lumber - Requirements
4	EN 300:2006	Oriented strand boards (OSB) – Definition, classification and specifications
5	EN 13986:2004+A1:2015	Wood-based panels for use in construction - Characteristics, evaluation of conformity and marking
6	EN 636:2012+A1:2015	Plywood - Specifications
7	EN 300:2006	Oriented strand boards (OSB) – Definition, classification and specifications
8	EN 312:2010	Particleboards - Specifications
9	EN 622-2:2004	Fibreboards – Specifications – Part 2: Requirements for hardboards
10	EN 622-3:2004	Fibreboards - Specifications - Part 3: Requirements for medium boards
11	EN 634-2:2007	Cement-bonded particleboards – Specifications – Part 2: Requirements for OPC bonded particleboards for use in dry, humid and external conditions
12	EN 13353:2011	Solid wood panels (SWP) – Requirements

blaugelb screws	Annex 1
Specifications of intended use	

A.1.3 Use Conditions (environmental conditions)

The corrosion protection of the blaugelb-screws is specified in Annex A.2.6. With regards to the use and the environmental conditions, the national provisions of the place of installation apply.

A.1.4 Installation provisions

EN 1995-1-1¹³ in conjunction with the respective national annex applies for the installation.

The screws are either driven into the wood-based member made of softwood without pre-drilling or in pre-drilled holes with a diameter not exceeding the inner thread diameter.

The screw holes in steel members shall be pre-drilled with an adequate diameter greater than the outer thread diameter.

A minimum of two screws shall be used for connections in load bearing timber structures. This does not apply for special situations specified in National Annexes to EN 1995-1-1.

If screws with an outer thread diameter $d \geq 8$ mm are driven into the wood-based member without pre-drilling, the structural solid or glued laminated timber, laminated veneer lumber and similar glued members shall be from spruce, pine or fir.

In the case of fastening battens on thermal insulation material on top of rafters the screws shall be driven in the rafter through the battens and the thermal insulation material without pre-drilling in one sequence.

By fastening screws in wood-based members the head of the screws shall be flush with the surface of the wood-based member. For pan head, oval head with washer face and hexagonal head the head part remains unconsidered.

electronic copy of the eta by dibt: eta-17/0605

¹³ EN 1995-1-1: 2004+AC:2006+A1:2008+A2:2014 Eurocode 5: Design of timber structures – Part 1-1: General - Common rules and rules for buildings

blaugelb screws	Annex 1
Installation provisions	

ANNEX 2 – Characteristic values of the load-carrying capacities

Table A.2.1 Characteristic load-carrying capacities of blaugelb screws

Outer thread diameter [mm]		3.0	3.5	4.0	4.5	5.0	6.0	8.0	10.0	12.0
Characteristic yield moment $M_{y,k}$ [Nm]	Carbon steel	1.6	2.3	3.3	4.5	5.9	9.5	20.0	30.0	60.0
	Stainless steel	0.9	1.4	1.9	2.6	3.4	5.5	12.0	21.0	-
Characteristic tensile strength $f_{tens,k}$ [kN]	Carbon steel	Other screws						15.1		
		Fully threaded wood construction screw	2.8	3.8	5.0	6.4	7.9	11.3	20.1	23.6
	Stainless steel	1.8	2.4	3.1	4.0	4.9	7.1	12.6	19.6	-
Characteristic torsional moment $f_{tor,k}$ [Nm]	Carbon steel	Other screws						22.0		
		Fully threaded wood construction screw	1.6	2.0	3.5	5.0	6.0	12.0	30.0	36.0
	Stainless steel	1.0	1.4	2.2	3.0	4.0	8.0	18.0	34.0	-

A.2.1 General

The penetration length of the threaded part of the screw in the wood-based members l_{ef} shall be

$$l_{ef} \geq \frac{4 \cdot d}{\sin \alpha}$$

where

α angle between screw axis and grain direction

d outer thread diameter of the screw.

The outer thread diameter of screws inserted in cross-laminated timber shall be at least 6 mm. The inner thread diameter d_1 of the screws shall be greater than the maximal width of the gaps in the layer.

A.2.2 Laterally loaded screws

A.2.2.1 General

The outer thread diameter d shall be used as effective diameter of the screw according to EN 1995-1-1.

The embedding strength for the screws in wood-based members or in wood-based panels shall be taken from EN 1995-1-1 or from national provisions that apply at the installation site unless otherwise specified in the following.

blaugelb screws	Annex 2
Characteristic load-bearing capacity values	

A.2.2.2 Cross laminated timber

The embedding strength for screws arranged in the edge surfaces parallel to the plane of cross laminated timber may be assumed according to equation (2.1) independent of the angle between screw axis and grain direction, $0^\circ \leq \alpha \leq 90^\circ$:

$$f_{h,k} = 20 \cdot d^{-0,5} \text{ in N/mm}^2 \tag{2.1}$$

unless otherwise specified in the technical specification of the cross laminated timber.

Where d is the outer thread diameter of the screws in mm.

Equation (2.1) is only valid for softwood layers. The provisions in the European Technical Approval/ Assessment or in national provisions of the cross laminated timber apply.

The embedding strength for screws in the wide face of cross laminated timber should be assumed as for solid timber based on the characteristic density of the outer layer. Where applicable, the angle between force and grain direction of the outer layer shall be taken into account. The direction of the lateral force shall be perpendicular to the screw axis and parallel to the wide face of the cross laminated timber.

A.2.3 Axially loaded screws

The axial slip modulus K_{ser} of the threaded part of a screw for the serviceability limit state shall be taken independent of angle α to the grain as:

$$K_{ser} = 780 \cdot d^{0,2} \cdot l_{ef}^{0,4} \text{ [N/mm]} \tag{2.2}$$

Where

d outer thread diameter of the screw [mm]

l_{ef} penetration length of the of the threaded part of the screw in the wood-based member [mm].

A.2.3.1 Axial withdrawal capacity

The characteristic withdrawal parameter at an angle $\alpha = 90^\circ$ to the grain based on a characteristic density of the wood-based member of 350 kg/m^3 is

$f_{ax,k} = 11.0 \text{ N/mm}^2$ for all screws with $d = 10.0 \text{ mm}$ and blaugelb wood construction-screws with $d = 8.0 \text{ mm}$

$f_{ax,k} = 12.5 \text{ N/mm}^2$ for the remaining screws.

The characteristic withdrawal parameter is also valid for softwood layers of cross-laminated timber.

For LVL a maximum characteristic density of 500 kg/m^3 shall be used in equation (8.40a) of EN 1995-1-1.

For OSB/3 and OSB/4 panels the characteristic withdrawal parameter at an angle of $\alpha = 90^\circ$ to the plane based on a characteristic density of the OSB panel of 600 kg/m^3 is

The minimum thickness of the OSB panel shall be 18 mm.

$f_{ax,k} = 10.0 \text{ N/mm}^2$ for blaugelb drilling screws with $4 \text{ mm} \leq d \leq 6 \text{ mm}$

electronic copy of the eta by dibt: eta-17/0605

blaugelb screws	Annex 2
Characteristic load-bearing capacity values	

English translation prepared by DIBt

For screws penetrating more than one layer of cross laminated timber the different layers may be taken into account proportionally. In the lateral surfaces of the cross laminated timber the screws shall be fully inserted in one layer of cross-laminated timber. The axial withdrawal capacity for screws arranged parallel to the plane of cross laminated timber, independent of the angle between screw axis and grain direction, $30^\circ \leq \alpha \leq 90^\circ$, may be calculated from:

$$R_{ax,k} = 20 \cdot d^{0,8} \cdot l_{ef}^{0,9} \quad \text{in N/mm}^2 \quad (2.3)$$

Where

d outer thread diameter of the screw [mm]

l_{ef} penetration length of the screw in the cross laminated timber [mm].

A.2.3.2 Head pull-through capacity

The characteristic value of the head pull-through parameter for blaugelb-screws for a characteristic density of 350 kg/m^3 of the timber and for wood-based panels like

- plywood according to EN 636 and EN 13986
- oriented Strand Board, OSB according to EN 300 and EN 13986
- particleboard according to EN 312 and EN 13986
- fibreboards according to EN 622-2, EN 622-3 and EN 13986
- Cement-bonded particle boards according to EN 634-2 and EN 13986,
- Solid-wood panels according to EN 13353 and EN 13986

with a thickness of more than 20 mm is

$$f_{head,k} = 9.4 \text{ N/mm}^2.$$

For wood-based panels a maximum characteristic density of 380 kg/m^3 and for LVL a maximum characteristic density of 500 kg/m^3 shall be used in equation (8.40b) of EN 1995-1-1.

The head diameter shall be equal to or greater than $1.8 \cdot d_s$, where d_s is the smooth shank or the inner thread diameter. Otherwise the characteristic head pull-through capacity in equation (8.40b) is for all wood-based materials:

$$F_{ax,\alpha,RK} = 0.$$

For wood based panels with a thickness $12 \text{ mm} \leq t \leq 20 \text{ mm}$ the characteristic value of the head pull-through parameter for blaugelb-screws is:

$$f_{head,k} = 8 \text{ N/mm}^2$$

For wood based panels with a thickness of less than 12 mm the characteristic head pull-through capacity for screws shall be based on a characteristic value of the head pull-through parameter of 8 N/mm^2 , and limited to 400 N complying with the minimum thickness of the wood based panels of $1.2 \cdot d$, with d as outer thread diameter and the values in Table A.2.2.

Table A.2.2 Minimum thickness of wood based panels

Wood based panel	Minimum thickness [mm]
Plywood	6
Fibreboards (hardboards and medium boards)	6
Oriented Strand Boards, OSB	8
Particleboards	8
Cement-bonded particle board	8
Solid wood Panels	12

In steel-to-timber connections the head pull-through capacity is not governing.

blaugelb screws	Annex 2
Characteristic load-bearing capacity values	

A.2.3.3 Compressive capacity of blaugelb wood construction screws with $d = 8$ mm and a full thread

The design axial capacity $F_{ax,Rd}$ of blaugelb wood construction screws with $d = 8$ mm and a full thread embedded in solid timber, glued solid timber or glued laminated timber made from softwood with an angle between screw axis and grain direction of $30^\circ \leq \alpha \leq 90^\circ$ is the minimum of the axial resistance against pushing-in and the buckling resistance of the screw.

$$F_{ax,Rd} = \min \{ f_{ax,d} \cdot d \cdot l_{ef}; \kappa_c \cdot N_{pl,d} \} \quad (2.4)$$

$f_{ax,d}$ design value of the axial withdrawal capacity of the threaded part of the screw [N/mm²]
 d outer thread diameter of the screw [mm]
 l_{ef} penetration length of the threaded part of the screw in the timber member [mm]

$$\kappa_c = 1 \quad \text{für } \bar{\lambda}_k \leq 0,2 \quad (2.5)$$

$$\kappa_c = \frac{1}{k + \sqrt{k^2 - \bar{\lambda}_k^2}} \quad \text{für } \bar{\lambda}_k > 0,2 \quad (2.6)$$

$$k = 0,5 \cdot \left[1 + 0,49 \cdot (\bar{\lambda}_k - 0,2) + \bar{\lambda}_k^2 \right] \quad (2.7)$$

and a relative slenderness ratio $\bar{\lambda}_k = \sqrt{\frac{N_{pl,k}}{N_{ki,k}}}$ (2.8)

where:

$N_{pl,k}$ characteristic plastic normal force related to the net cross-section

of the inner thread diameter: $N_{pl,k} = \pi \cdot \frac{d_1^2}{4} \cdot f_{y,k}$ (2.9)

$f_{y,k}$ characteristic yield strength, $f_{y,k} = 1000$ N/mm² for fully threaded blaugelb wood construction screws with $d = 8$ mm

d_1 inner thread diameter of the screw [mm]

$$N_{pl,d} = \frac{N_{pl,k}}{\gamma_{M1}} \quad (2.10)$$

γ_{M1} partial factor according to EN 1993-1-1 in conjunction with the particular national annex
 characteristic ideal elastic buckling load:

$$N_{ki,k} = \sqrt{c_h \cdot E_s \cdot I_s} \quad [\text{N}] \quad (2.11)$$

elastic foundation of the screw:

$$c_h = (0,19 + 0,012 \cdot d) \cdot \rho_k \cdot \left(\frac{90^\circ + \alpha}{180^\circ} \right) \quad [\text{N/mm}^2] \quad (2.12)$$

ρ_k characteristic density of the wood-based member [kg/m³], for LVL $\rho_k \leq 500$ kg/m³,
 α angle between screw axis and grain direction, $30^\circ < \alpha \leq 90^\circ$

modulus of elasticity:

$$E_s = 210000 \text{ N/mm}^2$$

second moment of area:

$$I_s = \frac{\pi \cdot d_1^4}{64} \quad [\text{mm}^4] \quad (2.13)$$

blaugelb screws	Annex 2
Characteristic load-bearing capacity values	

A.2.4 Spacing, end and edge distances of the screws and minimum thickness of the wood based material

Minimum thickness for structural members made from solid timber, glued laminated timber, glued solid timber, laminated veneer lumber and cross laminated timber is $t = 30$ mm for screws with $d \leq 8$ mm, $t = 40$ mm for screws with $d = 10$ mm and $t = 80$ mm for screws with $d = 12$ mm.

A.2.4.1 Laterally and/or axially loaded screws

Screws in pre-drilled holes

For blaugelb-screws in pre-drilled holes the minimum spacings, end and edge distances are given in EN 1995-1-1: 2004+AC:2006+A1:2008+A2:2014, clause 8.3.1.2 and Table 8.2 as for nails in pre-drilled holes. Here, the outer thread diameter d shall be considered.

Screws in non pre-drilled holes

For blaugelb-screws minimum spacing and distances are given in EN 1995-1-1: 2004+AC:2006+A1:2008+A2:2014, clause 8.3.1.2 and Table 8.2 as for nails in non-predrilled holes. Here, the outer thread diameter d shall be considered.

For Douglas fir members minimum spacing and distances parallel to the grain shall be increased by 50%.

Minimum distances from loaded or unloaded ends shall be at least $15 \cdot d$ for screws with outer thread diameter $d > 8$ mm and timber thickness $t < 5 \cdot d$.

Minimum distances from the unloaded edge perpendicular to the grain may be reduced to $3 \cdot d$ also for timber thickness $t < 5 \cdot d$, if the spacing parallel to the grain and the end distance is at least $25 \cdot d$.

A.2.4.2 Only axially loaded screws

For blaugelb wood construction screws with $d = 8$ mm and a full thread loaded only axially, the following minimum spacings, end and edge distances apply alternatively to paragraph A.2.4.1 for solid timber, glued laminated timber and similar glued products made from softwood based on a minimum timber thickness of $10 d$ and a minimum width of $8 d$ or 60 mm, whichever is the greater:

Spacing a_1 in a plane parallel to grain:	a_1	= $5 d$
Spacing a_2 perpendicular to a plane parallel to grain:	a_2	= $2.5 d$
End distance of the centre of gravity of the threaded part in the timber member:	$a_{1,c}$	= $10 d$
Edge distance of the centre of gravity of the threaded part in the timber member:	$a_{2,c}$	= $4 d$
Product of spacing a_1 and a_2 :	$a_1 \cdot a_2$	= $25 d^2$

For a crossed screw couple the minimum spacing between the crossing screws is $1.5 \cdot d$.

Are the spacing, end and edge distances less than the distances and thicknesses given in EN 1995-1-1 the verification of resistance according to EN 1995-1-1: 2004+AC:2006+A1:2008+A2:2014, clause 8.7.2 (1) the failure along the circumference of a group of screws has to be considered also for connections without steel plates.

blaugelb screws	Annex 2
Spacing, end and edge distances	

English translation prepared by DIBt

A.2.4.3 Cross laminated timber

The minimum requirements for spacing, end and edge distances of screws in the plane or edge surfaces of cross laminated timber are summarised in Table A.2.3. The definition of spacing, end and edge distance is shown in Figure 2.1 and Figure 2.2. The minimum spacing, end and edge distances in the edge surfaces are independent of the angle between screw axis and grain direction. They may be used based on the following conditions:

- Minimum thickness of cross laminated timber: $10 \cdot d$
- Minimum penetration depth in the edge surface: $10 \cdot d$

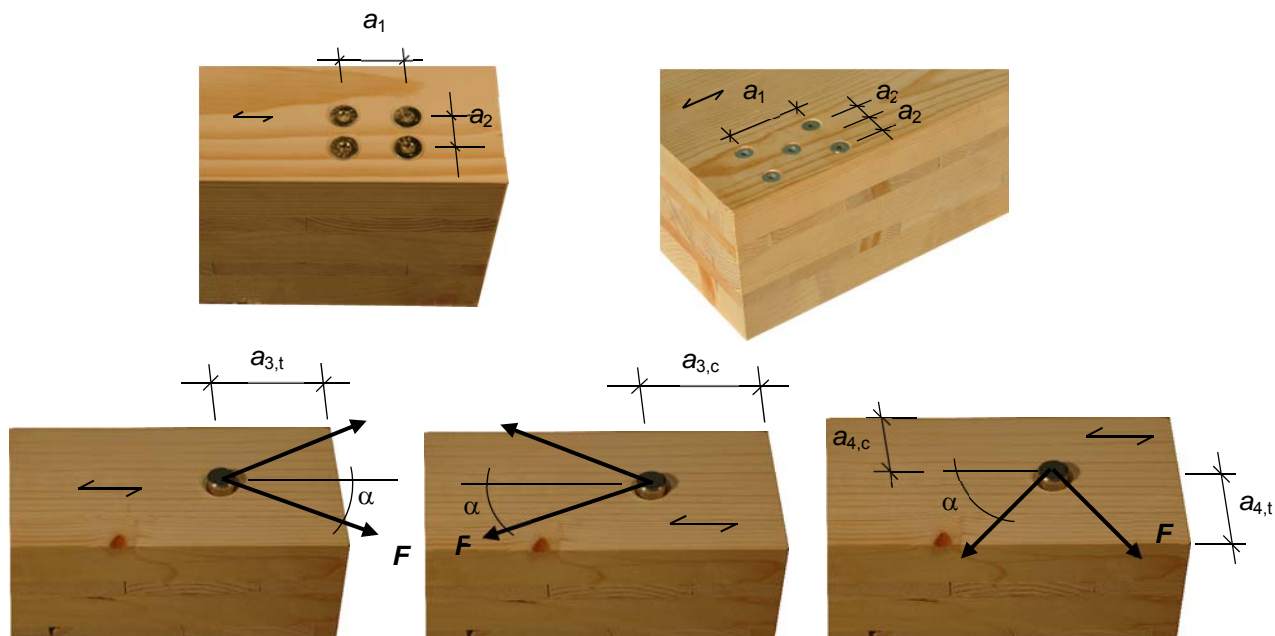

Figure 2.1: Definition of spacing, end and edge distances in the plane surface

Table A.2.3: Minimum spacing, end and edge distances of screws in the plane or edge surfaces of cross laminated timber

	a_1	$a_{3,t}$	$a_{3,c}$	a_2	$a_{4,t}$	$a_{4,c}$
Plane surface (see Figure 2.1)	$4 \cdot d$	$6 \cdot d$	$6 \cdot d$	$2,5 \cdot d$	$6 \cdot d$	$2,5 \cdot d$
Edge surface (see Figure 2.2)	$10 \cdot d$	$12 \cdot d$	$7 \cdot d$	$4 \cdot d$	$6 \cdot d$	$3 \cdot d$

electronic copy of the eta by dibt: eta-17/0605

blaugelb screws	Annex 2
Spacing, end and edge distances	

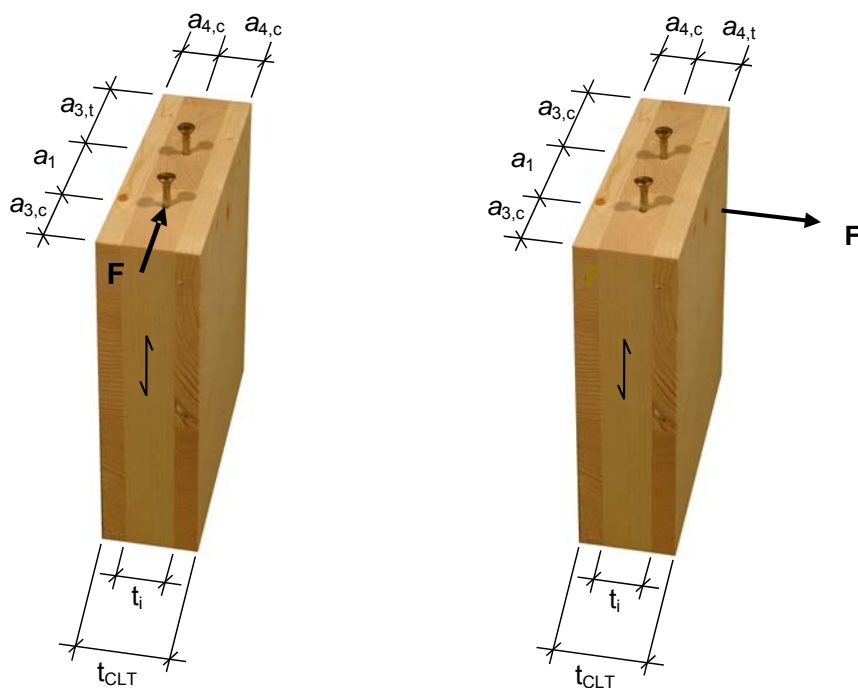
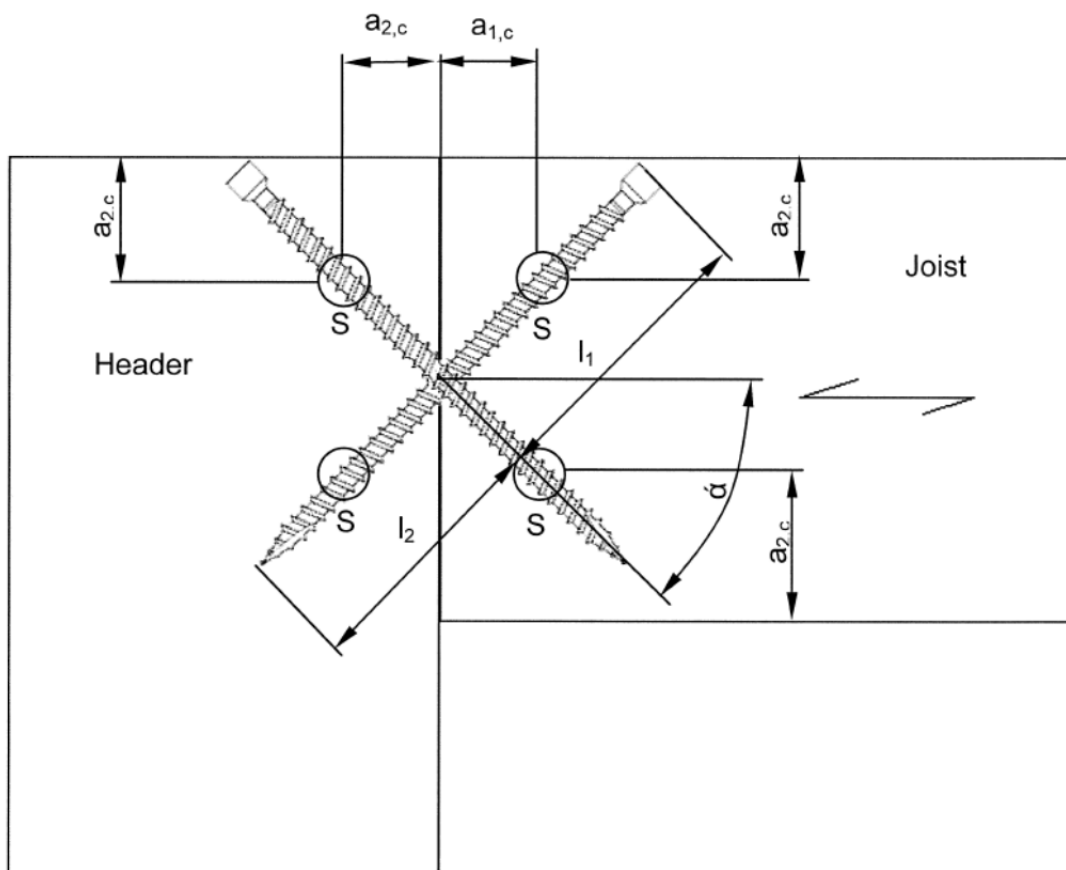

Figure 2.2: Definition of spacing, end and edge distances in the edge surface

blaugelb screws	Annex 2
Spacing, end and edge distances	

Examples of use for blaugelb wood construction screws with $d = 8$ mm and a full thread

Header-joist connection



S Centroid of the part of the screw in the timber

electronic copy of the eta by dibt: eta-17/0605

blaugelb screws	Annex 2
Use examples	

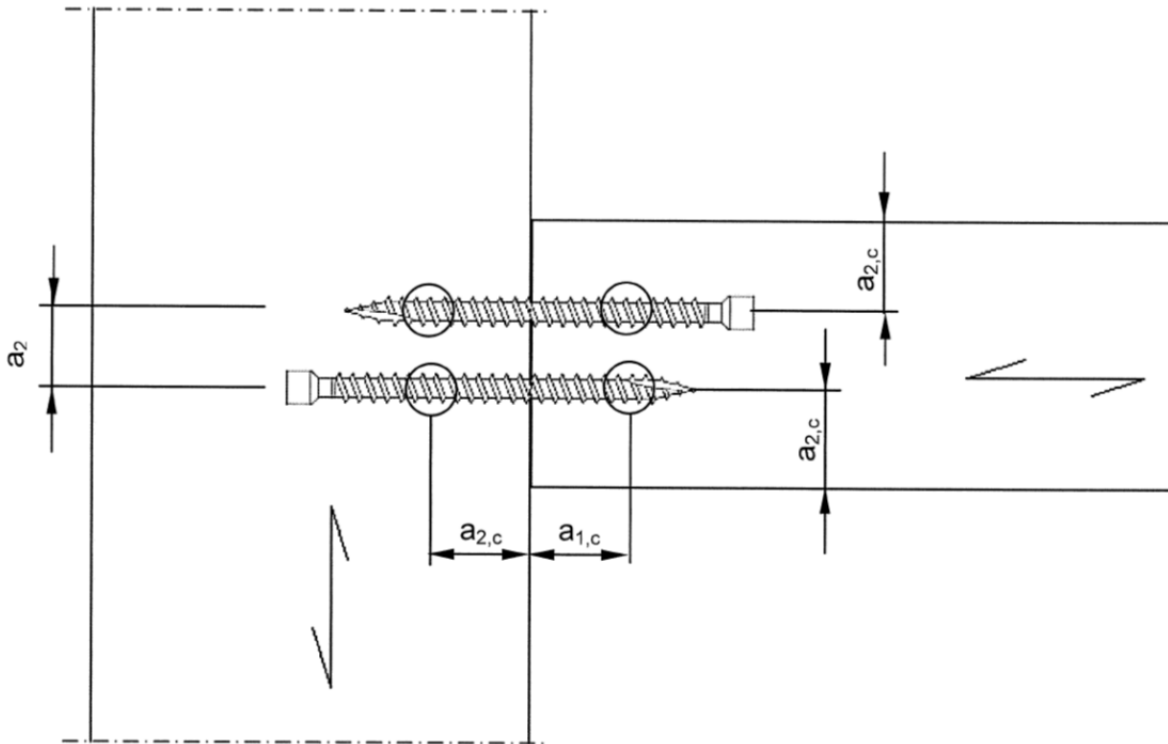

electronic copy of the eta by dibt: eta-17/0605

blaugelb screws	Annex 2
Use examples	

Parallel inclined screws to connect wood-based members

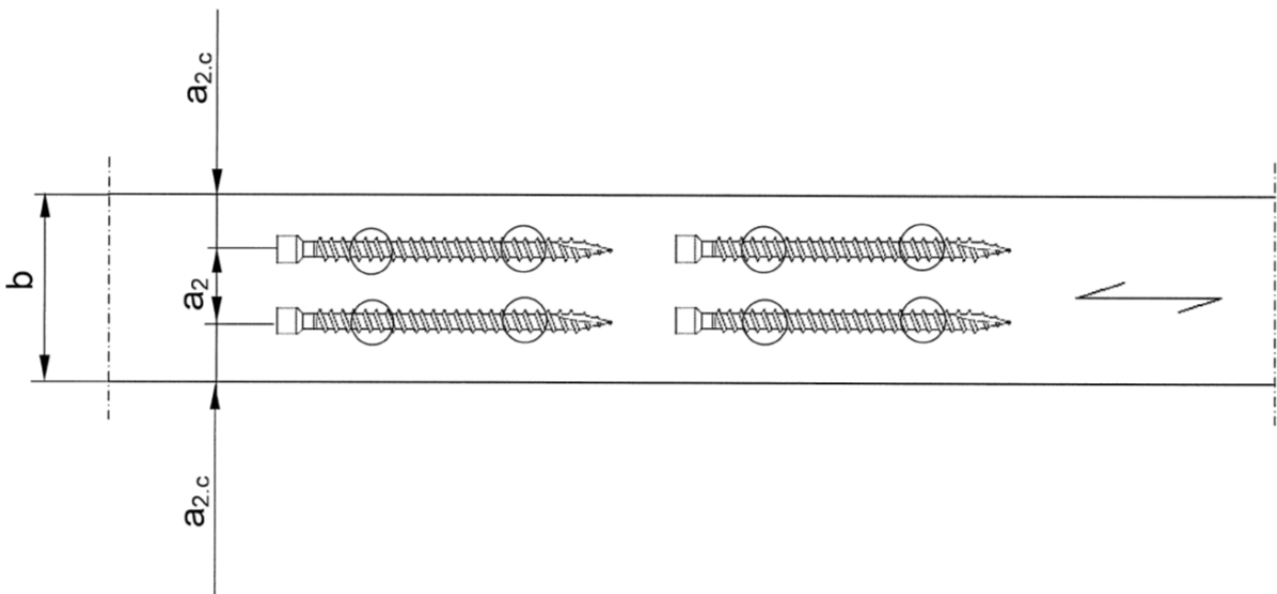
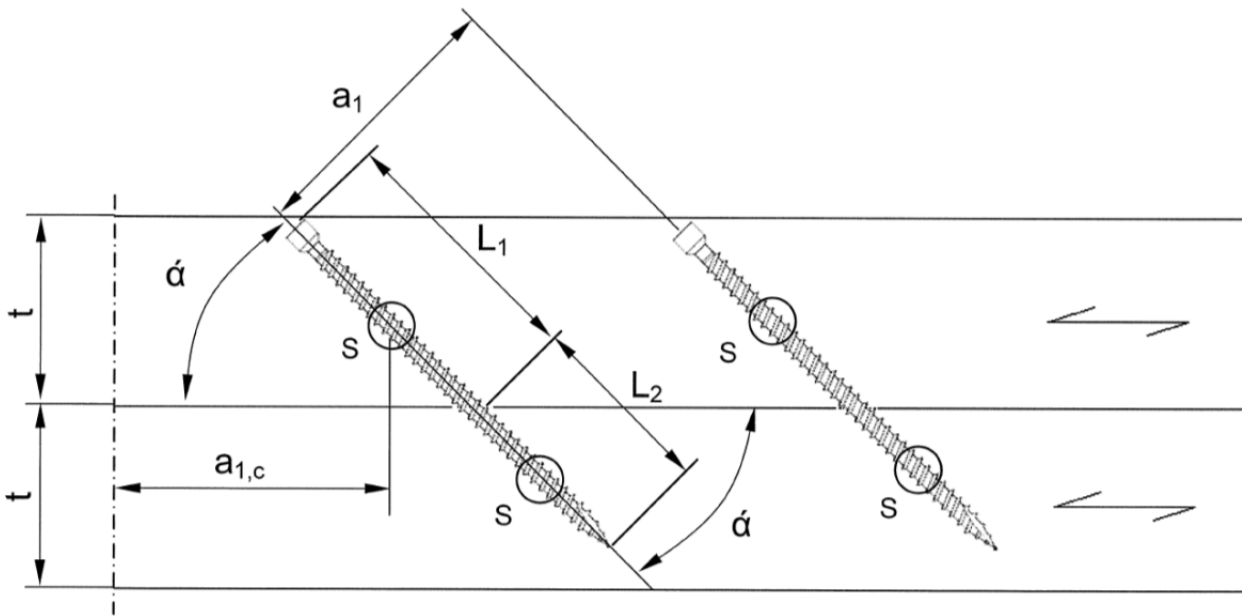

- S Centroid of the part of the screw in the timber
- t Thickness of the wood-based member $t \geq 12 \cdot d$
- b Width of the wood-based member $t \geq 8 \cdot d$ or 60 mm, whichever is the greater

electronic copy of the eta by dibt: eta-17/0605

blaugelb screws	Annex 2
Use examples	

A.2.5 Insertion moment

The ratio between the characteristic torsional strength $f_{tor,k}$ and the mean value of insertion moment $R_{tor,mean}$ fulfills the requirement for all screws.

A.2.6 Durability against corrosion

Screws made from carbon steel are electrogalvanised and yellow or blue chromated. The mean thickness of the zinc coating of the screws is 5 μm .

Steel no. 1.4567 (A2L), 1.4578 (A4L), 1.4539 or 1.4529 is used for screws made from stainless steel.

blaugelb screws	Annex 2
Insertion moment and durability against corrosion	

ANNEX 3 - Compression reinforcement perpendicular to the grain

A.3.1 General

Only blaugelb wood construction screws with $d = 8$ mm and a full thread shall be used for compression reinforcement perpendicular to the grain. The provisions are valid for reinforcing timber members made from solid timber, glued solid timber or glued laminated timber made from softwood.

The compression force shall evenly be distributed to the screws used as compression reinforcement.

The screws are driven into the timber member perpendicular to the contact surface under an angle between the screw axis and the grain direction of 45° to 90° . The screw heads shall be flush with the timber surface.

A.3.2 Design

For the design of reinforced contact areas the following conditions shall be met independently of the angle between the screw axis and the grain direction.

The design resistance of a reinforced contact area is:

$$R_{90,d} = \min \left\{ \begin{array}{l} \kappa_{c,90} \cdot B \cdot \ell_{ef,1} \cdot f_{c,90,d} + n \cdot \min \{ R_{ax,d}; \kappa_c \cdot N_{pl,d} \} \\ B \cdot \ell_{ef,2} \cdot f_{c,90,d} \end{array} \right\} \quad (3.1)$$

where:

$\kappa_{c,90}$ parameter according to EN 1995-1-1: 2004+AC:2006+A1:2008+A2:2014: 2008, 6.1.5

B bearing width [mm]

$\ell_{ef,1}$ effective contact length according to EN 1995-1-1: 2004+AC:2006+A1:2008+A2:2014, 6.1.5 [mm]

$f_{c,90,d}$ design compressive strength perpendicular to the grain [N/mm^2]

n number of reinforcing screws, $n = n_0 \cdot n_{90}$

n_0 number of reinforcing screws arranged in a row parallel to the grain

n_{90} number of reinforcing screws arranged in a row perpendicular to the grain

$$R_{ax,d} = f_{ax,d} \cdot d \cdot \ell_{ef} \quad [\text{N}] \quad (3.2)$$

$f_{ax,d}$ design value of the axial withdrawal capacity of the threaded part of the screw [N/mm^2]

d outer thread diameter of the screw [mm]

$$\kappa_c \cdot N_{pl,d} = \frac{\kappa_c \cdot N_{pl,k}}{\gamma_{M1}} \quad \text{with } \kappa_c \cdot N_{pl,k} \text{ according to Table A.3.1} \quad [\text{N}] \quad (3.3)$$

$\ell_{ef,2}$ effective contact length in the plane of the screw tips (see Figure 3.1) [mm]

$\ell_{ef,2} = \{ \ell_{ef} + (n_0 - 1) \cdot a_1 + \min(\ell_{ef}; a_{1,c}) \}$ for end supports (see Figure 3.1 left)

$\ell_{ef,2} = \{ 2 \cdot \ell_{ef} + (n_0 - 1) \cdot a_1 \}$ for intermediate supports (see Figure 3.1 right)

ℓ_{ef} threaded length of the screw in the timber member [mm]

γ_{M1} partial factor according to EN 1993-1-1¹⁴ in conjunction with the particular national annex

¹⁴ EN 1993-1-1:2005 Eurocode 3: Design of steel structures. Part 1-1: General rules and rules for buildings

blaugelb screws	Annex 3
Compression reinforcement perpendicular to the grain	

Table A.3.1: Characteristic load-carrying capacity $\kappa_c \cdot N_{pl,k}$ for fully threaded blaugelb wood construction screws in N

ρ_k [kg/m ³]	d [mm]
	8.0
310	11800
350	12200
380	12500
410	12700
450	13000

The characteristic load-carrying capacity $\kappa_c \cdot N_{pl,k}$ are based on a characteristic yield strength of the blaugelb fully threaded wood construction screws of $f_{y,k} = 1000$ N/mm².

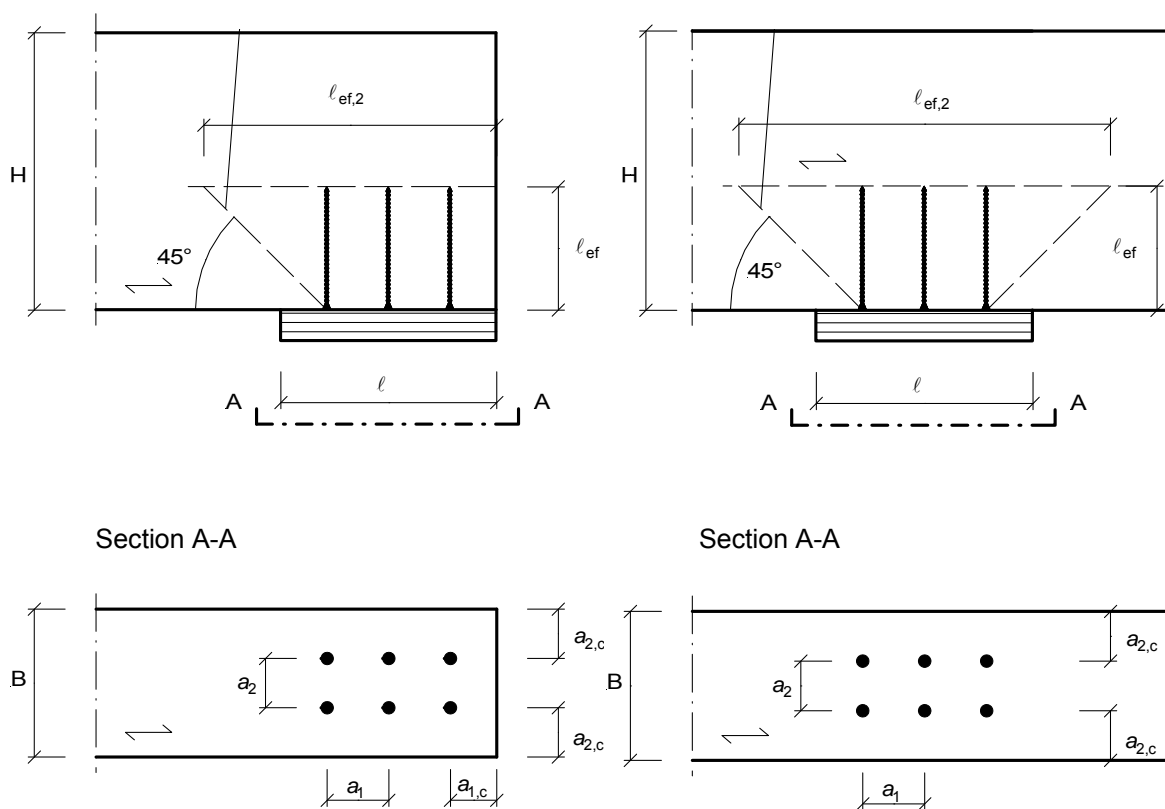

Figure 3.1: Reinforced end support (left) and reinforced intermediate support (right)

blaugelb screws	Annex 3
Compression reinforcement perpendicular to the grain	

ANNEX 4 - Fastening of thermal insulation material on top of rafters

A.4.1 General

Blaugelb-screws with an outer thread diameter of at least 6 mm may be used for the fixing of thermal insulation material on top of rafters. The thickness of the thermal insulation material may be up to 400 mm. The thermal insulation material shall be applicable as insulation on top of rafters according to national provisions that apply at the installation site. The minimum compressive stress of the thermal insulation material at 10 % deformation, measured according to EN 826¹⁵, shall be $\sigma_{(10\%)} = 0.05 \text{ N/mm}^2$.

The battens have to be from solid timber according to EN 338/ EN 14081-1. The minimum thickness t and the minimum width b of the battens are given as follows:

$$b_{\min} = 50 \text{ mm} \quad t_{\min} = 30 \text{ mm}.$$

The minimum width of the rafters is 60 mm.

The spacing between screws e_s shall be not more than 1.75 m.

Friction forces shall not be considered for the design of the characteristic axial capacity of the screws.

The anchorage of wind suction forces as well as the bending stresses of the battens, respectively, shall be considered for design. Screws perpendicular to the grain of the rafter (angle $\alpha = 90^\circ$) may be arranged if necessary.

A.4.2 Parallel inclined screws and thermal insulation material in compression

A.4.2.1 Mechanical model

The system of rafter, thermal insulation material on top of rafter and counter battens parallel to the rafter may be considered as a beam on elastic foundation. The counter batten represents the beam, and the thermal insulation material on top of the rafter the elastic foundation. The counter batten is loaded perpendicular to the axis by point loads F_b transferred by regularly spaced battens. Further point loads F_s are caused by the shear load of the roof due to dead and snow load, which are transferred from the screw heads into the counter battens.

¹⁵ EN 826:2013 Thermal insulating products for building applications - Determination of compression behaviour

blaugelb screws	Annex 4
Fastening of thermal insulation material on top of rafters	

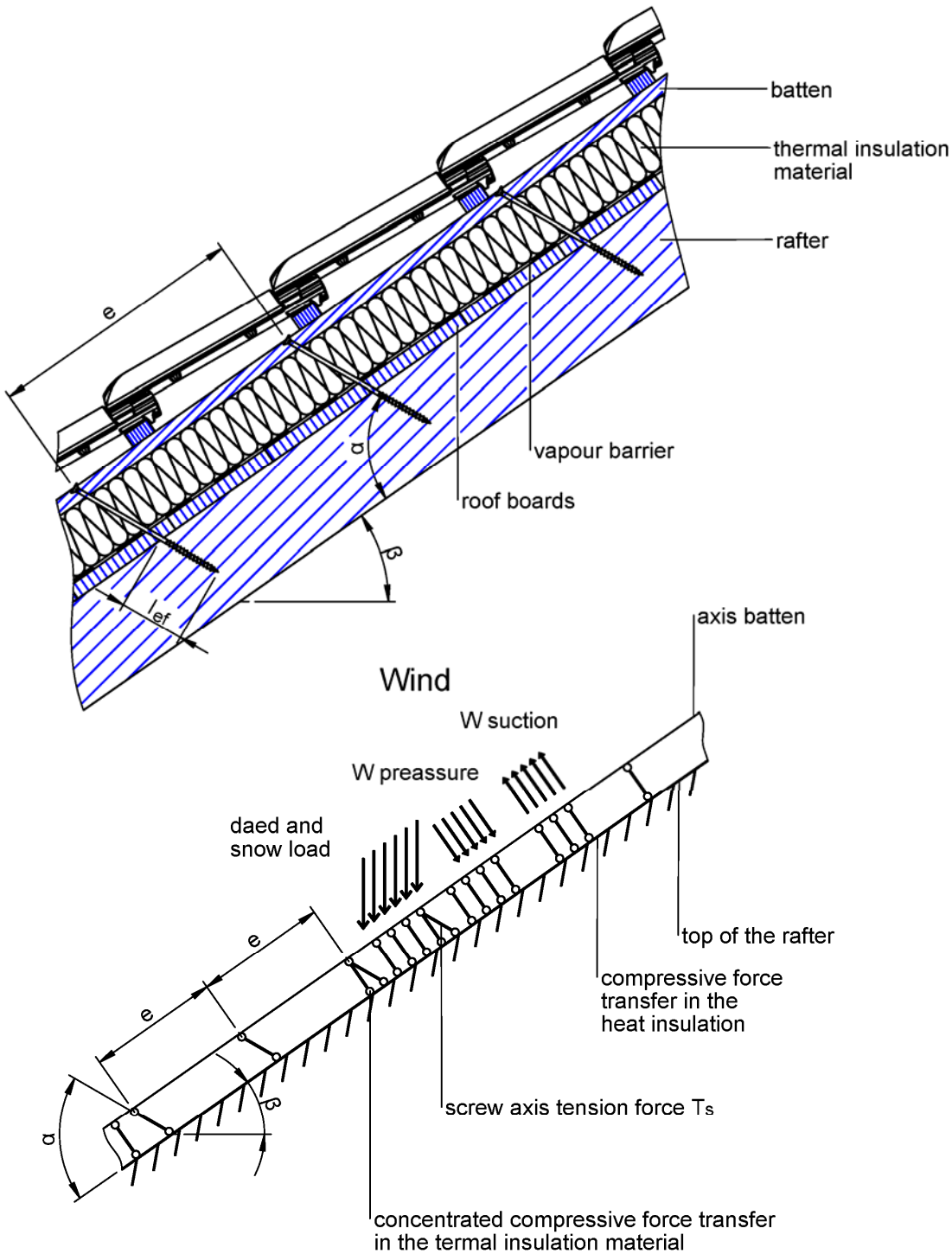

Figure 4.1 Fastening of the thermal insulation material on top of rafters - structural system

electronic copy of the eta by dibt: eta-17/0605

blaugelb screws	Annex 4
Fastening of thermal insulation material on top of rafters	

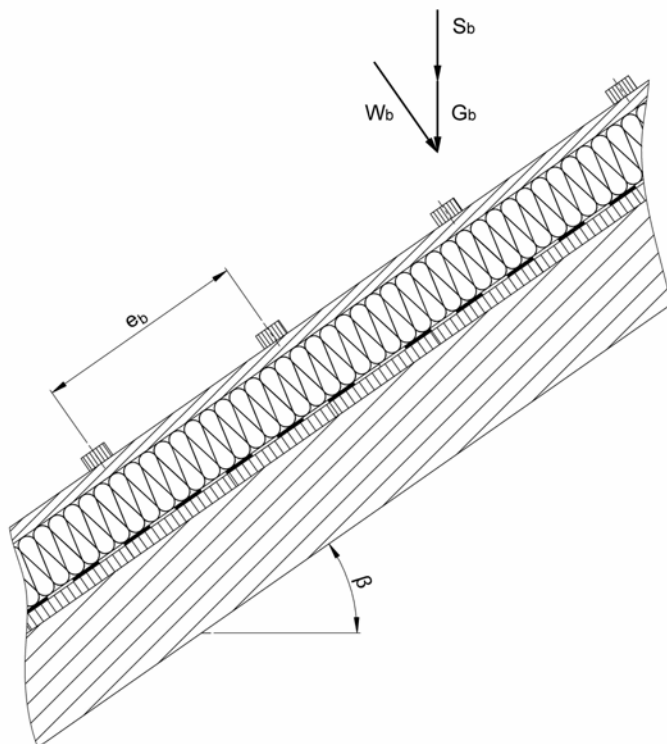

Figure 4.2 Point loads F_b perpendicular to the battens

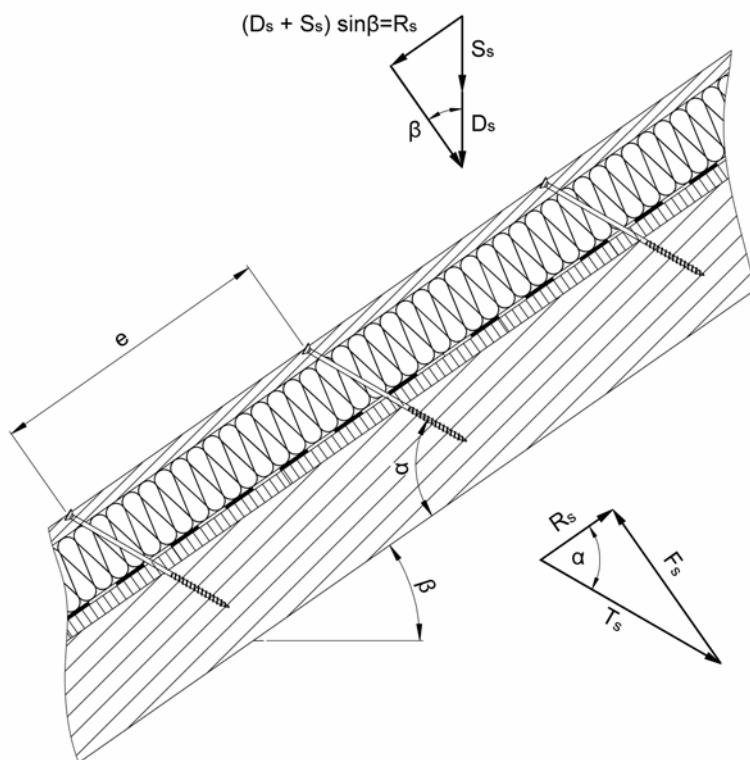

Figure 4.3 Point loads F_s perpendicular to the battens, load application in the area of the screw heads

electronic copy of the eta by dibt: eta-17/0605

blaugelb screws	Annex 4
Fastening of thermal insulation material on top of rafters	

A.4.2.2 Design of the battens

It's assumed that the spacing between the counter battens exceeds the characteristic length l_{char} .

The characteristic values of the bending stresses are calculated as:

$$M_k = \frac{(F_b + F_s) \cdot l_{char}}{4} \quad (4.1)$$

where

$$l_{char} = \text{characteristic length } l_{char} = \sqrt[4]{\frac{4 \cdot EI}{w_{ef} \cdot K}} \quad (4.2)$$

EI = bending stiffness of the batten

K = coefficient of subgrade

w_{ef} = effective width of the thermal insulation material

$F_{b,k}$ = point loads perpendicular to the battens

$F_{s,k}$ = point loads perpendicular to the battens, load application in the area of the screw heads

The coefficient of subgrade K may be calculated from the modulus of elasticity E_{HI} and the thickness t_{HI} of the thermal insulation material if the effective width w_{ef} of the thermal insulation material under compression is known. Due to the load extension in the thermal insulation material the effective width w_{ef} is greater than the width of the batten or rafter, respectively. For further calculations, the effective width w_{ef} of the thermal insulation material may be determined according to:

$$w_{ef} = w + t_{HI} / 2 \quad (4.3)$$

where

w = minimum from width of the batten or rafter, respectively

t_{HI} = thickness of the thermal insulation material

$$K = \frac{E_{HI}}{t_{HI}} \quad (4.4)$$

The following condition shall be satisfied:

$$\frac{\sigma_{m,d}}{f_{m,d}} = \frac{M_d}{W \cdot f_{m,d}} \leq 1 \quad (4.5)$$

For the calculation of the section modulus W the net cross section shall be considered.

The characteristic values of the shear stresses shall be calculated according to:

$$V_k = \frac{(F_b + F_s)}{2} \quad (4.6)$$

The following condition need to be satisfied:

$$\frac{\tau_d}{f_{v,d}} = \frac{1.5 \cdot V_d}{A \cdot f_{v,d}} \leq 1 \quad (4.7)$$

For the calculation of the cross section area the net cross section shall be considered.

blaugelb screws	Annex 4
Fastening of thermal insulation material on top of rafters	

A.4.2.3 Design of the thermal insulation material

The characteristic value of the compressive stresses in the thermal insulation material shall be calculated according to:

$$\sigma_k = \frac{1.5 \cdot F_{b,k} + F_{s,k}}{2 \cdot l_{char} \cdot w} \quad (4.8)$$

The design value of the compressive stress shall not be greater than 110 % of the compressive strength at 10 % deformation calculated according to EN 826.

A.4.2.4 Design of the screws

The screws are loaded predominantly axial. The characteristic value of the axial tension force in the screw may be calculated from the shear loads of the roof R_s :

$$T_{S,k} = \frac{R_{S,k}}{\cos \alpha} \quad (4.9)$$

The load-carrying capacity of axially loaded screws is the minimum design value of the axial withdrawal capacity of the threaded part of the screw, the head pull-through capacity of the screw and the tensile capacity of the screw according to Annex 2.

In order to limit the deformation of the screw head for thermal insulation material with thickness over 220 mm or with compressive strength below 0.12 N/mm², respectively, the axial withdrawal capacity of the screws shall be reduced by the factors k_1 and k_2 :

$$F_{ax,\alpha,Rd} = \min \left\{ \frac{f_{ax,d} \cdot d \cdot l_{ef} \cdot k_1 \cdot k_2}{1.2 \cdot \cos^2 \alpha + \sin^2 \alpha} \cdot \left(\frac{\rho_k}{350} \right)^{0.8}; f_{head,d} \cdot d_h^2 \cdot \left(\frac{\rho_k}{350} \right)^{0.8}; \frac{f_{tens,k}}{\gamma_{M2}} \right\} \quad (4.10)$$

where:

- $f_{ax,d}$ design value of the axial withdrawal parameter of the threaded part of the screw [N/mm²]
- d outer thread diameter of the screw [mm]
- l_{ef} penetration length of the threaded part of the screw in the rafter [mm], $l_{ef} \geq 40$ mm
- ρ_k characteristic density of the wood-based member [kg/m³], for LVL the assumed characteristic density shall not exceed 500 kg/m³
- α angle α between screw axis and grain direction, $30^\circ \leq \alpha \leq 90^\circ$
- $f_{head,d}$ design value of the head pull-through parameter of the screw [N/mm²]
- d_h head diameter [mm]
- $f_{tens,k}$ characteristic tensile capacity of the screw according to Annex 2 [N]
- γ_{M2} partial factor according to EN 1993-1-1 in conjunction with the particular national annex
- k_1 $\min \{1; 220/t_{HI}\}$
- k_2 $\min \{1; \sigma_{10\%}/0.12\}$
- t_{HI} thickness of the thermal insulation material [mm]
- $\sigma_{10\%}$ compressive stress of the thermal insulation material under 10 % deformation [N/mm²]

If equation (4.10) is fulfilled, the deflection of the battens does not need to be considered when designing the load-carrying capacity of the screws.

blaugelb screws	Annex 4
Fastening of thermal insulation material on top of rafters	

English translation prepared by DIBt

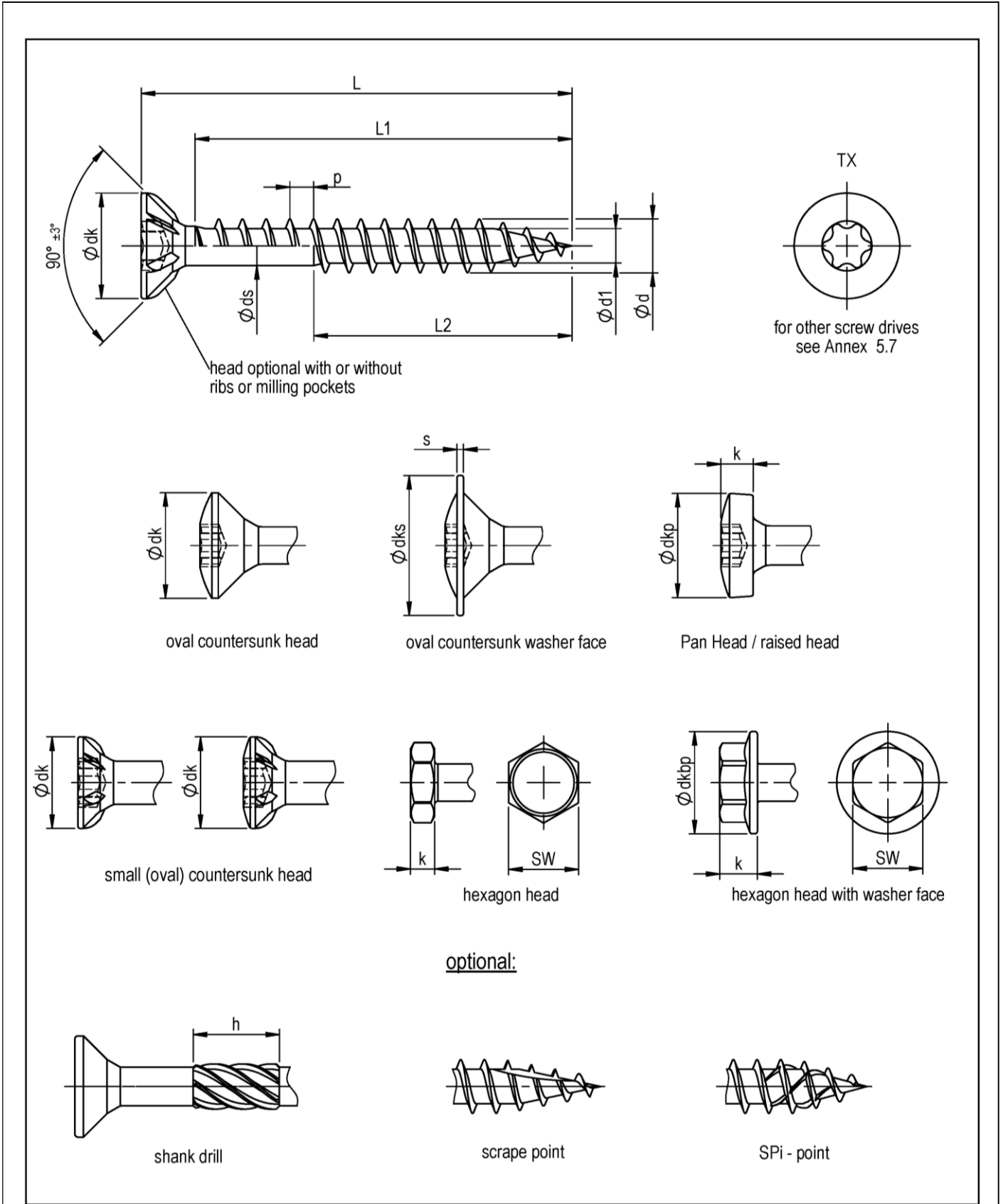

electronic copy of the eta by dibt: eta-17/0605

blaugelb screws

blaugelb R2 screws with single thread made of carbon steel

Annex 5.1

blaugelb R2 screws with single thread				
thread dimensions				h
$\varnothing d_{-0,3}$	$\varnothing d1^{+0,3}$	$\varnothing ds \pm 0,2$	$p \pm 10\%$	
3,0 ^{+0,1}	1,8	2,2	1,35	5,0
3,5 ^{+0,1}	2,1	2,6	1,6	6,0
4,0 ^{+0,1}	2,4	2,8	1,8	7,0
4,5 ^{+0,1}	2,6	3,1	2,0	8,0
5,0 ^{+0,2}	3	3,6	2,2	8,0
6,0 ^{+0,2}	3,6	4,1	2,6	10,0

head shapes										
$\varnothing d$	(oval) countersunk head	small (oval) counterunk head	oval countersunk washer face		Panhead / raised head		hexagon head		hexagon head with washer face	
	$dk \pm 0,5$	$dk \pm 0,3$	$dks \pm 0,3$	$s \pm 0,2$	$dkp_{-0,5}$	$k \pm 0,2$	SW	k	dkbp max.	k
3,0	6,0		7,1	0,6	6,0	2,3				
3,5	7,0	5,0	8,1	0,6	7,0	2,6				
4,0	8,0	6,0	9,2	0,9	8,0	3,0				
4,5	9,0	7,0	10,3	0,9	9,0	3,2				
5,0	10,0	8,0	11,0	1,1	10,0	3,7	8	3,5	11,4	3,5
6,0	12,0	11,0	13,8	1,1	12,0	4,5	10	4,0		

L*	3,0		3,5		4,0		4,5		5,0		6,0	
	L1 $\pm 2,0$	L2 $\pm 2,0$	L1 $\pm 2,0$	L2 $\pm 2,0$	L1 $\pm 2,0$	L2 $\pm 2,0$	L1 $\pm 2,0$	L2 $\pm 2,0$	L1 $\pm 3,0$	L2 $\pm 3,0$	L1 $\pm 3,0$	L2 $\pm 3,0$
16 -0,90	12											
20 -1,05	16		16		16							
25 -1,05	21	16	21	16	21	16	21	16	21			
30 -1,05	26	21	26	21	26	21	26	21	26		26	
35 -1,25	31	21	31	21	31	21	31	21	31		31	
40 -1,25	36	26	36	26	36	26	36	26	36	26	36	
45 -1,25	41	31	41	31	41	31	41	31	41	31	41	
50 -1,25		31	46	31	46	31	46	31	46	31	46	31
55 -1,50					51	36	51	36	51	36	51	36
60 -1,50					56	36	56	36	56	36	56	36
70 -1,50						42	66	42	66	42	66	42
80 -1,50						50		50	76	50	76	50
90 -1,50										60		60
100 -1,50										60		60
110 -1,75										70		70
120 -2,00										70		70
-180												
200 -3,00												80
-300												

*deviant lengths between $L_{min} < L < L_{max}$ possible

blaugelb screws

blaugelb R2 screws with single thread made of carbon steel

Annex 5.2

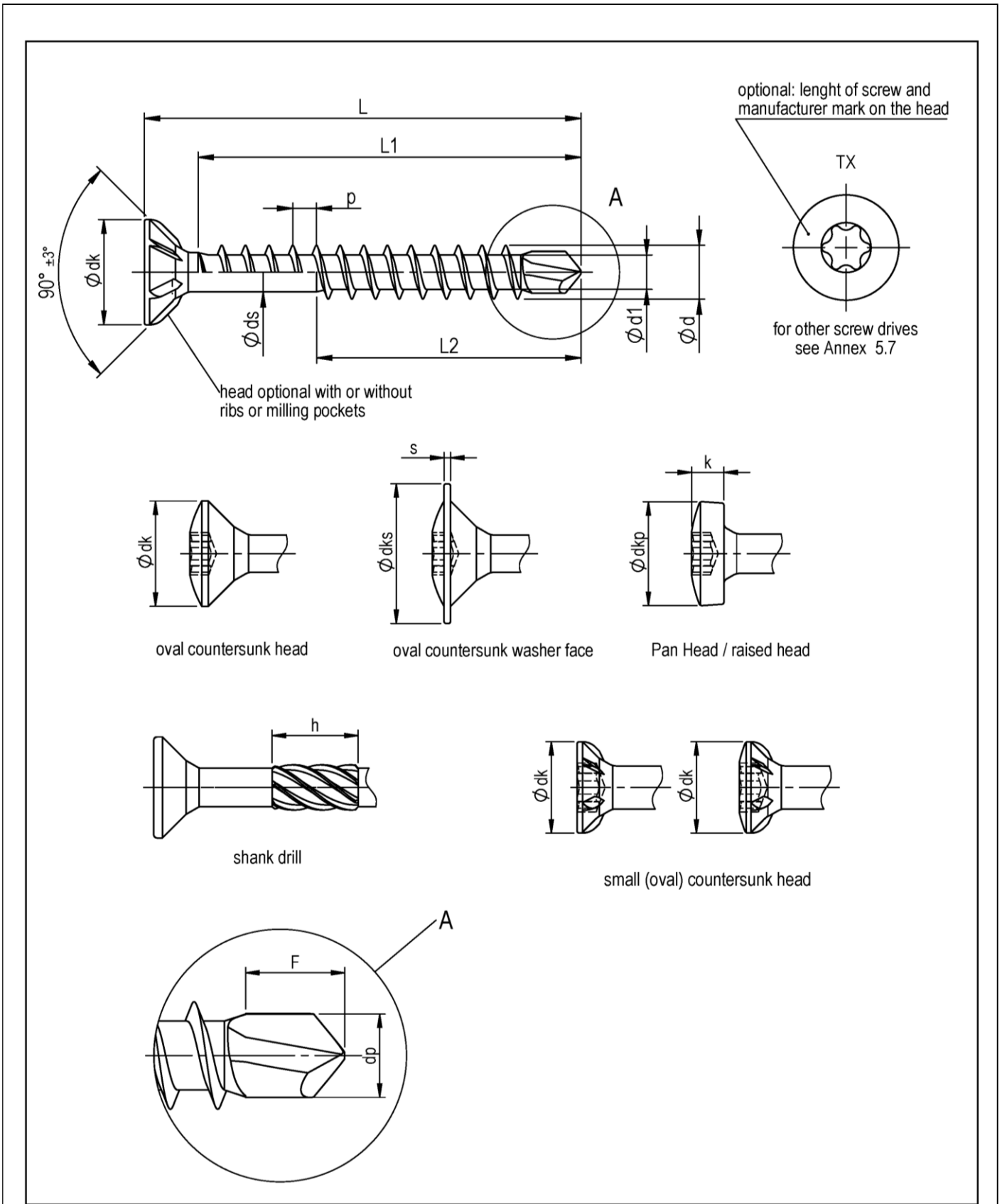

blaugelb screws

blaugelb drilling screws with tapping point made of carbon steel and stainless steel

Annex 5.3

blaugelb drilling screws						
thread dimensions				h	F ca.	dp
$\varnothing d_{-0,3}$	$\varnothing d1^{+0,3}$	$\varnothing ds \pm 0,2$	$p \pm 10\%$			
3,5 ^{+0,1}	2,0 _{-0,1}	2,6	1,6	6,0	2,8	2,2
4,0 ^{+0,1}	2,4 (2,6) _{-0,1}	2,9	1,8	7,0	3,0	2,9
4,5 ^{+0,1}	2,6 (3,0) _{-0,1}	3,3	2,0	8,0	3,7	3,2
5,0 (5,3) ^{+0,2}	3,0 (3,7) _{-0,1}	3,5 (4,0)	2,2	8,0	4,5	3,9
6,0 (6,5) ^{+0,2}	3,6 (4,6) _{-0,1}	4,4 (5,0)	2,6 (2,2)	10,0	4,5	4,9

*(values in brackets only for screws made of stainless steel)

head shapes						
$\varnothing d$	(oval) countersunk head	oval countersunk washer face		panhead / raised head		small (oval) countersunk head
	$dk \pm 0,5$	$dk_s \pm 0,3$	$s \pm 0,2$	$dk_p \pm 0,5$	$k \pm 0,2$	$dk \pm 0,3$
3,5	7,0	8,1	0,6	7,0	2,6	5,0
4,0	8,0	9,2	0,9	8,0	3,0	6,0
4,5	9,0	10,3	0,9	9,0	3,2	7,0
5,0	10,0	11,0	1,1	10,0	3,7	8,0
6,0	12,0	13,8	1,1	12,0	4,5	11,0

L*	3,0		3,5		4,0		4,5		5,0		6,0	
	L1 $\pm 2,0$	L2 $\pm 2,0$	L1 $\pm 2,0$	L2 $\pm 2,0$	L1 $\pm 2,0$	L2 $\pm 2,0$	L1 $\pm 2,0$	L2 $\pm 2,0$	L1 $\pm 3,0$	L2 $\pm 3,0$	L1 $\pm 3,0$	L2 $\pm 3,0$
16 _{-0,90}	12											
20 _{-1,05}	16		16		16							
25 _{-1,05}	21	18	21	18	21	18	21	18	21			
30 _{-1,05}	26	21	26	21	26	21	26	21	26		26	
35 _{-1,25}	31	26	31	26	31	26	31	26	31		31	
40 _{-1,25}	36	26	36	26	36	26	36	26	36	26	36	26
45 _{-1,25}	41	28	41	28	41	28	41	28	41	28	41	28
50 _{-1,25}		33	46	33	46	33	46	33	46	33	46	35
55 _{-1,50}				38	51	38	51	38	51	38	51	35
60 _{-1,50}					56	38	56	38	56	38	56	35
70 _{-1,50}						48	66	48	66	48	66	47
80 _{-1,50}						48		48	76	48	76	57
90 _{-1,50}										58		57
100 _{-1,50}										58		66
110 _{-1,75}										66		66
120 _{-2,00}											66	66
180 _{-3,00}												66
200 _{-3,00}												66
300 _{-3,00}												66

*deviant lengths between $L_{min} < L < L_{max}$ possible

blaugelb screws

blaugelb drilling screws with tapping point made of carbon steel and stainless steel

Annex 5.4

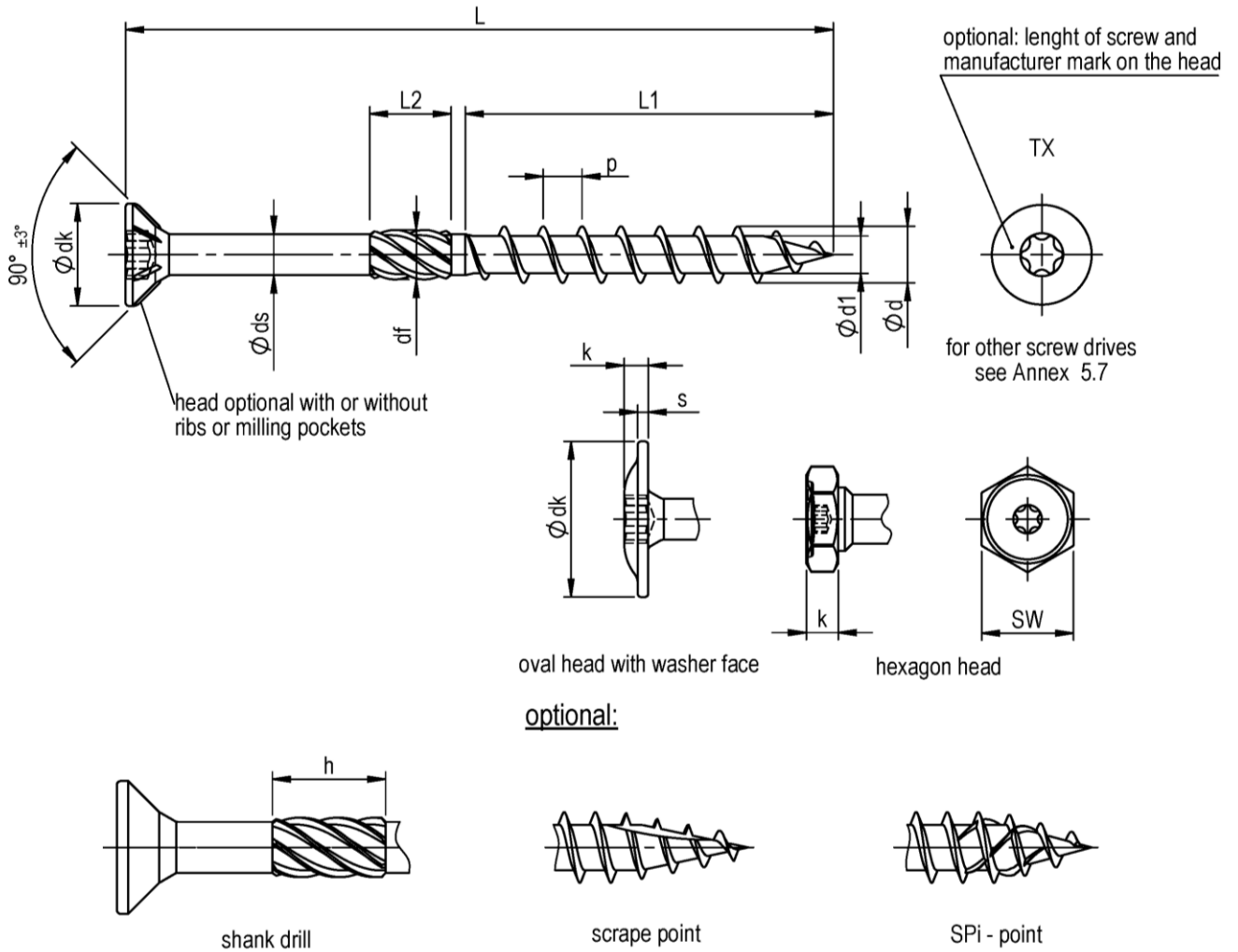

blaugelb wood construction screws with coarse thread						head shapes					
thread dimensions				shank drill		countersunk head	oval haed with washer face			hexagon head	
$\varnothing d_{\pm 0,3}$	$\varnothing d1 \pm 0,3$	$\varnothing ds \pm 0,2$	$p \pm 10\%$	$\varnothing df \pm 0,3$	$L2 \pm 2$	$\varnothing dk \pm 0,6$	$\varnothing dk \pm 1,0$	$k \pm 0,3$	$s \pm 0,3$	SW	$k \pm 1,0$
8,0 ^{+0,2}	5,2	5,8	5,5	7,0	12,0	14,5	20	4,0	1,6	12	4,5
10,0 ^{+0,2}	6,25	7,0	6,6	8,25	12,0	17,8	24	4,8	2,0	15	5,5
12,0 ^{+0,2}	7,12	8,2	6,8	9,5	12,0	20,0	30	5,5	2,4	17	6,5

nominal length L	$\varnothing 8,0$	$\varnothing 10,0$	$\varnothing 12,0$
	L1	L1	L1
80 - 120 -1,75		60 ± 1,5	
121 - 500 -2,5		80 ± 1,5	

electronic copy of the eta by dibt: eta-17/0605

blaugelb screws

blaugelb wood construction screws coarse thread made of carbon steel

Annex 5.5

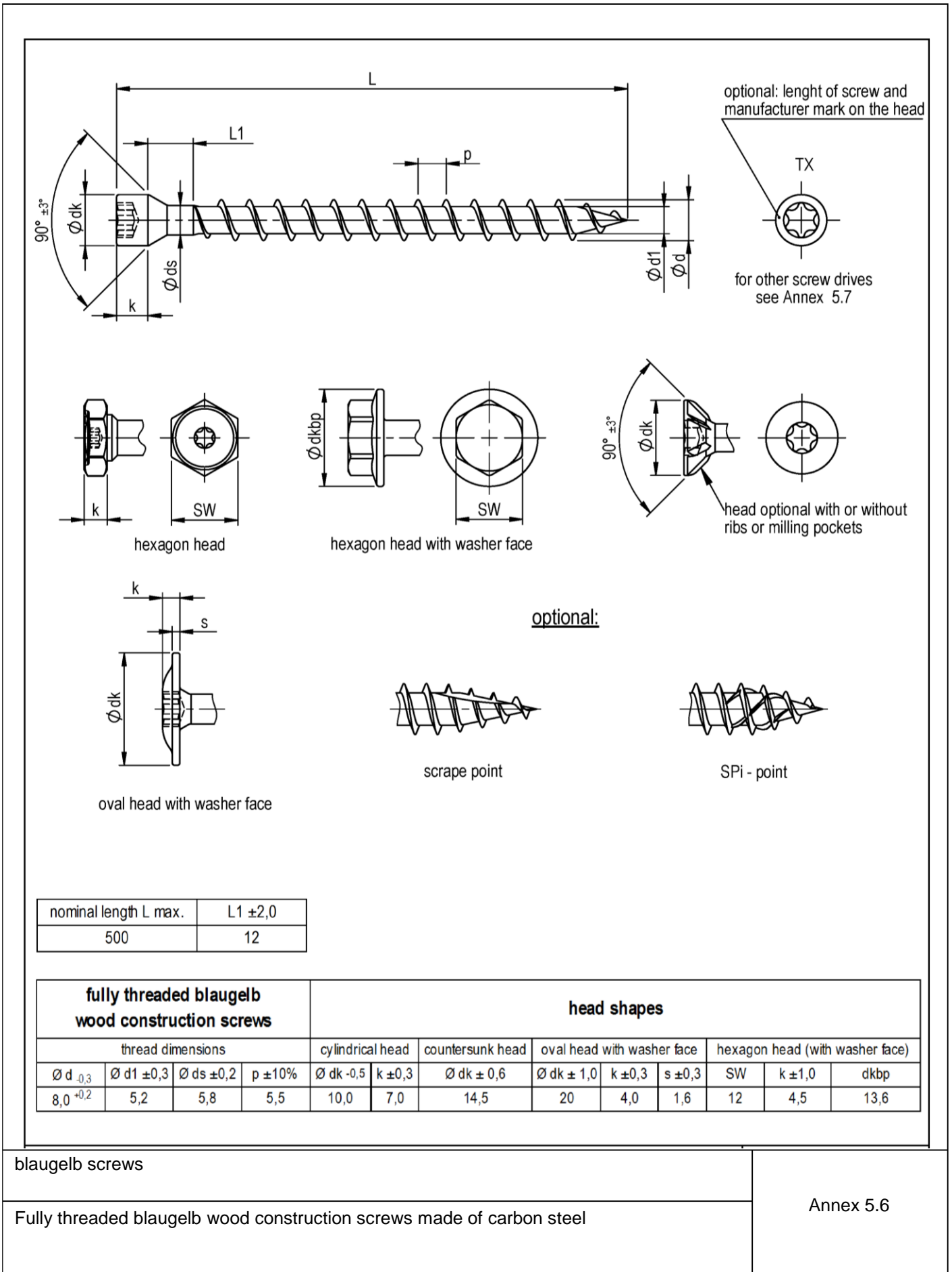

cross recess type H

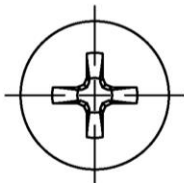

cross recess type Z

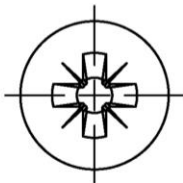

hexagon socket

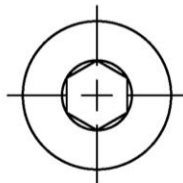

hexagon head

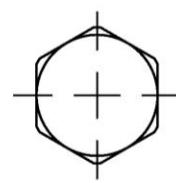

TX

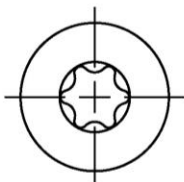

TX Pin

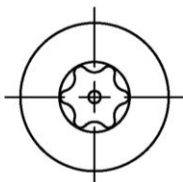

TX Ttap

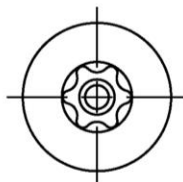

SIT

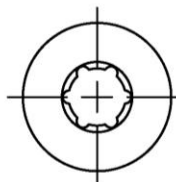

sizes of screw drives

screw drive	Ø 3,0	Ø 3,5	Ø 4,0	Ø 4,5	Ø 5,0	Ø 5,5	Ø 6,0	Ø 7,0	Ø 8,0	Ø 10	Ø 12
cross recess type H	1	1 / 2	2	2	2	2 / 3	3	3			
cross recess type Z											
TX	10	10 / 15 / 20	15 / 20	20	20 / 25	20 / 25	25 / 30	30	30 / 40	40 / 50	40 / 50
TX Pin											
TX Ttap											
SIT											
hexagon head					SW8		SW10		SW12	SW15	SW17
hexagon socket					SW4		SW5		SW6		

blaugelb screws

Screw drives

Annex 5.7