

# blaugelb Plinth Thermal Insulation Profile EPS HS for BT 194 GU-thermostep 204

For perfect insulation results.



Effective insulation offering high potential savings

Permanently eliminates energy weak points on components installed on floor slabs

Cradle to Cradle Certified® at the Silver level

Prevents damage caused by moisture and mould formation

High load transfer, low weight

Force-locking screwing in the threshold structure

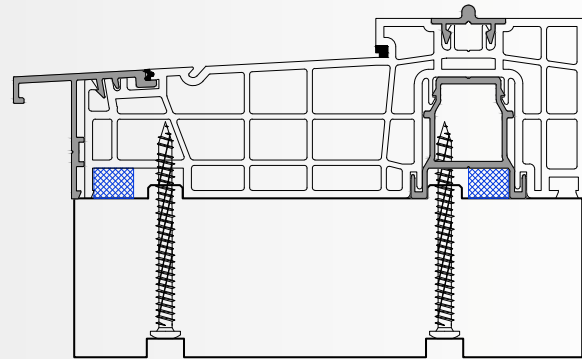

## Product features:

The blaugelb Plinth Thermal Insulation Profile EPS HS is made from a high-density EPS (expanded polystyrene) and offers the best possible heat and moisture protection on lifting/sliding doors made from wood, wood/aluminium, aluminium and plastic.

The blaugelb Plinth Thermal Insulation Profile EPS HS is sturdy, durable and is exceptionally quick and easy to fit. The blaugelb Plinth Thermal Insulation Profile EPS HS enables thermal separation and reduces potential thermal bridges of conventional plastic profiles with steel reinforcement. It is dimensionally stable, 100 % free of HCFCs, HFCs and HBCDs and tested to be low in pollutants according to EMICODE EC1 Plus. The blaugelb Plinth Thermal Insulation Profile EPS HS was specially developed for fitting as a floor recess profile under lifting/sliding door threshold systems.

By virtue of the innovative dovetail joint, the blaugelb Plinth Thermal Insulation Profile EPS HS can be positively interlocked, to create any desired length. The dovetail joint reduces the amount of waste, possibly even avoiding waste altogether, while the 1,200 mm length of the individual profiles is ideal for transport and storage (Europallet). Thanks to their low

weight and compact dimensions, blaugelb Plinth Thermal Insulation Profiles EPS HS are unbeatably quick and straightforward to process.

With the tongue and groove joint, the two blaugelb Plinth Thermal Insulation Profiles EPS HS which are to be joined have two grooves each and two tongues each and can be coupled in height one under the other.

The contoured mount guarantees quick and easy installation of the profile with the blaugelb Frame Screw Fix FK-T30 and precise positioning thanks to the contour cutting. This prevents the formation of a hollow chamber between the sill connection profile and the frame, and airtightness is achieved thanks to the process-safe sealing.

## Product benefits:

- Effective insulation offering high potential savings
- Permanently eliminates energy weak points on components installed on floor slabs and enhances indoor comfort
- Prevents damage caused by moisture and mould formation
- High load transfer
- Low weight
- Force-locking screwing in the threshold structure
- Cradle to Cradle Certified® at the Silver level

## Technical data:

Material:	High-density EPS (expanded polystyrene), high ductility
Colour:	Grey
Compressive load bearing capacity at max. total deformation of 2 %:	1,260 kg/dm <sup>2</sup>
Compressive load bearing capacity at 170 x 53 mm: (blaugelb Shim Block HST)	12,533 N
Fire behaviour: DIN 4102-1:1998-05 / DIN EN 13501-1:2019-05	B2 / Class E
Thermal transmittance value U-value:	0.210 W/m <sup>2</sup> K
Thermal conductivity nominal value λ <sub>10</sub> : DIN EN 12667:2001-05	0.0403 W/m*k
Water vapour diffusion resistance: DIN EN ISO 12086	228 μ
Air permeability: EN 12207	Class 4
Airborne sound insulation: DIN EN ISO 717-1	min. R <sub>w</sub> 28.5 dB ± 1.2 dB
Bending strength: DIN EN 12089	≥ 2,490 kPa
Compression stress (10 %) compression: DIN EN DIN EN 13163:2017 / EN 826:2013-05	≥ 1,435 kPa
Shear strength: DIN EN ISO 14130	0.217 N/mm <sup>2</sup>
Dimensional strength: DIN ISO 75-1	Short-term up to +95 °C Long-term up to +85 °C
Dimensional stability: DIN EN 13163:2015-04	Very high, including outdoor weathering
Water absorption after 28 days under water: DIN 12087	≤ 0.5 vol. %
Screw withdrawal values: blaugelb Frame Screw Fix FK-T30 7.5 x L mm Screw-in depth 40 / 60 / 80 / 100 mm sfs window sill screw 4.5 x 35 mm	F <sub>RAZ</sub> 1.33 / 2.20 / 2.87 / 3.76 kN F <sub>RAZ</sub> 0.51 kN
Compatibility with conventional building materials:	Compatible, except for solvents, solvent-bearing materials and materials that are not polystyrene-compatible
Ageing resistance:	Mould-proof, does not rot
Waste code:	Code no. 170604 Code no. 170904

Product name	PU	Item no.
blaugelb Plinth Thermal Insulation Profile EPS HS 192 x 90 x 1200 mm <b>GU-thermostep 204 BT194</b>	1 pc.	3100009643
blaugelb Plinth Thermal Insulation Profile EPS HS 192 x 100 x 1200 mm <b>GU-thermostep 204 BT194</b>	1 pc.	3100003614
blaugelb Plinth Thermal Insulation Profile EPS HS 192 x 110 x 1200 mm <b>GU-thermostep 204 BT194</b>	1 pc.	3100009644
blaugelb Plinth Thermal Insulation Profile EPS HS 192 x 120 x 1200 mm <b>GU-thermostep 204 BT194</b>	1 pc.	3100003615

## Processing note:

Seal between the lifting/sliding door threshold and Plinth Thermal Insulation Profile HS is achieved with blaugelb Hybrid Polymer Crystal.

## Delivery and storage form:

Store in its original packaging. Current packaging: Use of a PE stretch film.

## Disposal:

According to Waste Catalogue Ordinance:  
Code no. 170604 (single-grade insulating material EPS)  
Code no. 170904 (mixed construction waste)

## Safety note:

According to the available specifications and guidelines, the product is not a hazardous substance.

Product name	PU	Item no.
blaugelb Plinth Thermal Insulation Profile EPS HS 192 x 30 x 1200 mm <b>GU-thermostep 204 BT194</b>	1 pc.	3100003609
blaugelb Plinth Thermal Insulation Profile EPS HS 192 x 40 x 1200 mm <b>GU-thermostep 204 BT194</b>	1 pc.	3100003610
blaugelb Plinth Thermal Insulation Profile EPS HS 192 x 50 x 1200 mm <b>GU-thermostep 204 BT194</b>	1 pc.	3100003611
blaugelb Plinth Thermal Insulation Profile EPS HS 192 x 60 x 1200 mm <b>GU-thermostep 204 BT194</b>	1 pc.	3100003612
blaugelb Plinth Thermal Insulation Profile EPS HS 192 x 70 x 1200 mm <b>GU-thermostep 204 BT194</b>	1 pc.	3100009642
blaugelb Plinth Thermal Insulation Profile EPS HS 192 x 80 x 1200 mm <b>GU-thermostep 204 BT194</b>	1 pc.	3100003613

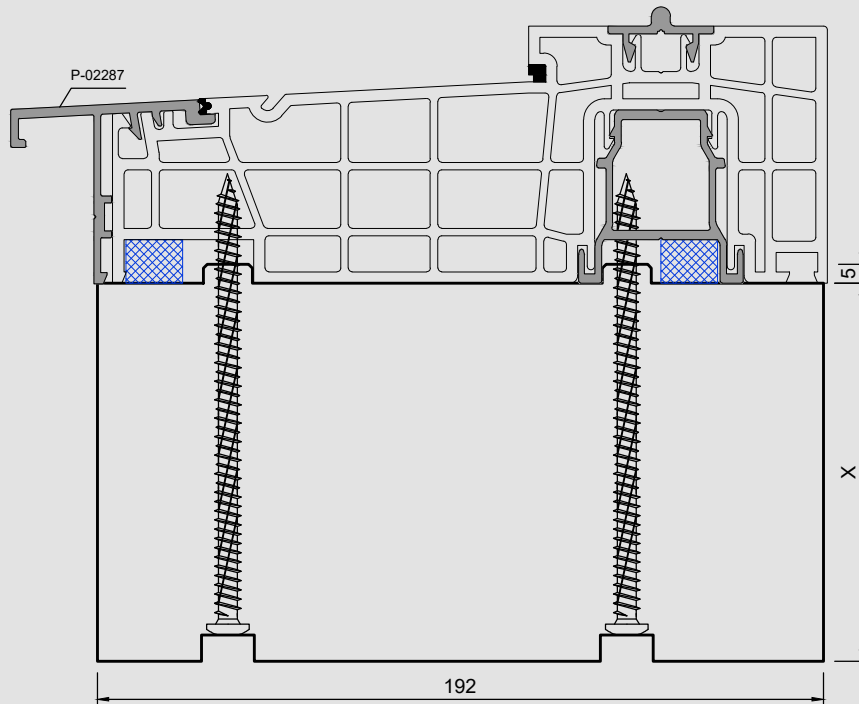

X = 30, 40, 50, 60, 70, 80, 90, 100, 110, 120 mm

The information provided in this document corresponds to the information and technical details available to the best of our knowledge. However, this does not constitute a guarantee pursuant to section 443 of the German Civil Code (BGB). Our processing instructions are to be considered only as general guidelines and may differ in the individual case due to the range of possible uses and applications. They do therefore not automatically exempt the user from carrying out their own tests. We reserve the right to make technical modifications and enhancements at any time.